



B204 - SUBMITTAL CHECKLIST AND DETAILS DECK

This submittal checklist is intended to assist you in preparing and submitting a complete application. Once your application is determined to be counter complete, a review for technical completeness is conducted and you may be required to submit additional information in order to proceed with further review of your application.

Before You Apply for Your Project

- **Decks not exceeding 200 square feet in area, that are not more than 30 inches above grade at any point, are not attached to a dwelling and do not serve the front door do not require a permit per IRC R105.2.**
- Regardless if a building permit is required or not, you may still need approval from the planning department for shoreline, critical areas, steep slopes or zoning related restrictions.
- If the property is served by septic system, check with the Kitsap Public Health District at 360.728.2235 to identify the exact location of the property’s septic system components including all drainfield reserve areas.
- If you hire someone to build your deck, they must be a registered contractor—it’s the law in Washington State. To verify your contractor’s information, contact the Washington State Department of Labor and Industries. Phone: 360.415.4000; website: www.LNI.wa.gov).

Section 1 - Submittal Requirements

Use the column to the left to check off items included with your application.

✓	Form #	Required Submittal Items
	B101	1. All submittal items must be received in electronic format only.
		2. Building Permit Application
		3. Site plan
		4. Construction plans - must carry design professional's original stamp and signature if prepared by a licensed professional.
		5. Engineered plans and calculations, if applicable - must carry engineer's original stamp and signature.
		6. Kitsap Public Health District Documentation All residential additions or major remodel projects are required to have review and approval from Kitsap Public Health District 360.728.2235 . The documentation to submit to PCD will be one of the following: <div style="margin-left: 20px;"> <input type="checkbox"/> Accepted or Concurrent Review BSA (Building Site Application) <input type="checkbox"/> Accepted or Concurrent Review BC (Building Clearance) <input type="checkbox"/> Accepted Building Clearance Exemption </div>
	B109	7. Residential Surface & Stormwater Management (SSWM) worksheet

Fees are due at the time of submittal. Accepted forms of payment:

- Cash
- Check/Cashier's Check - Make checks payable to City of Bainbridge Island (COBI)
- Credit Cards: Discover, Visa, or MasterCard. A convenience fee will be assessed to each credit/debit card transaction.

Section 2 – Technically Complete Details

Detailed application requirements are noted below.

Code Requirement	Code Reference
All wood must be pressure treated or of natural resistance to decay.	IRC R317.1
Fasteners, hangers, nails, etc, must be stainless steel, hot-dipped galvanized, or as specifically required for the specified wood preservative used.	IRC R317.3.1
Lateral connection is required to resist overturning (see attached for figure)	IRC R507.2.3
Ledger boards must be attached with lag screws or bolts with washers to the building and all connections between the deck and dwelling must be flashed with metal flashing.	IRC R507.2
Joists are of appropriate size to support imposed loads. The span of a joist is measured from the centerline of bearing at one end of the joist to the centerline of bearing at the other end of the joist and does not include length of the overhangs. Use Table 1 to determine joist span based on lumber size and joist spacing.	IRC R502.3
All decks, balconies or porches, open sides of landings and stairs which are more than 30" above grade or a floor below must be protected by a guardrail not less than 36" high (42" for commercial or common areas of multi-family dwellings). Open guardrails and stair railings require intermediate rails or an ornamental pattern such that a ball 4" in diameter cannot pass through.	IRC R312
Footings are of appropriate size to support imposed loads and extend a minimum of 12" below grade. (see construction details for footing sizes)	IRC 403.1.4
Columns and posts exposed to the weather or to water splash must be supported by and connected to concrete piers or metal pedestals projecting above grade. Columns and posts in contact with the ground or embedded in concrete or masonry must be of special pressure treated wood approved for ground contact. Knee braces are required if the distance from grade to the top of the post exceeds 4'.	IRC R317.1.2
Positive connections required to secure posts to beams	IRC R502.9
Decks should not overhang beams by more than two feet, nor should beams overhang posts by more than a foot at the ends unless a specific design is calculated. Floor joist spacing at 24" on center requires 2x decking, and floor joist spacing at 16" on center requires 1x decking.	IRC R502.3
Deck stairs (exterior stairways) shall be provided with a source of illumination at the top landing, controlled from within the dwelling or by automatic means.	IRC R311.7.8

Section 3 – Inspections

Inspectors visit the construction site during the project to make sure that it complies with building code requirements (see General Building Code Requirements, below). Most decks require a minimum of two inspections:

- Footing Inspection—Inspected after the holes are dug and rebar placed but prior to the pouring of concrete.
- Framing Inspection—Inspected after all framing, blocking and bracing are in place and prior to closing the construction so as to make it inaccessible for inspection. This inspection can be completed at the time of the final inspection if all parts of the framing will be visible and accessible at the final inspection.
- Final inspection to be made upon completion of the deck and finish grading.

The inspector may conduct one or more inspections during one visit if they can observe all work done. Additionally, the inspector may make or require other inspections to ascertain compliance with the provisions of the code.

Residential Deck Requirements

Drawing - page 1

NOTE:
For framing member sizes, see page 3.

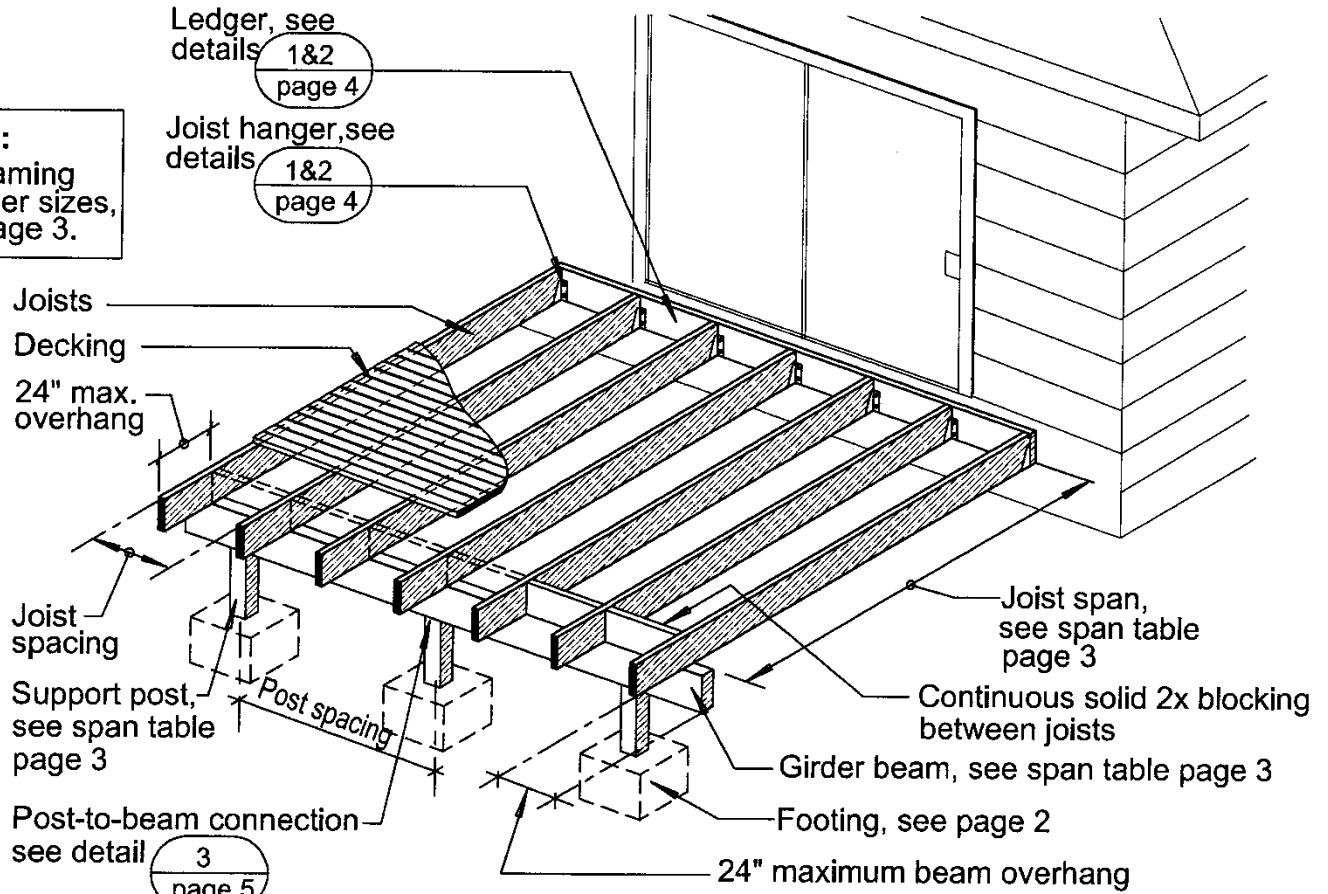

Typical Deck

Residential Deck Requirements

Drawing - page 2

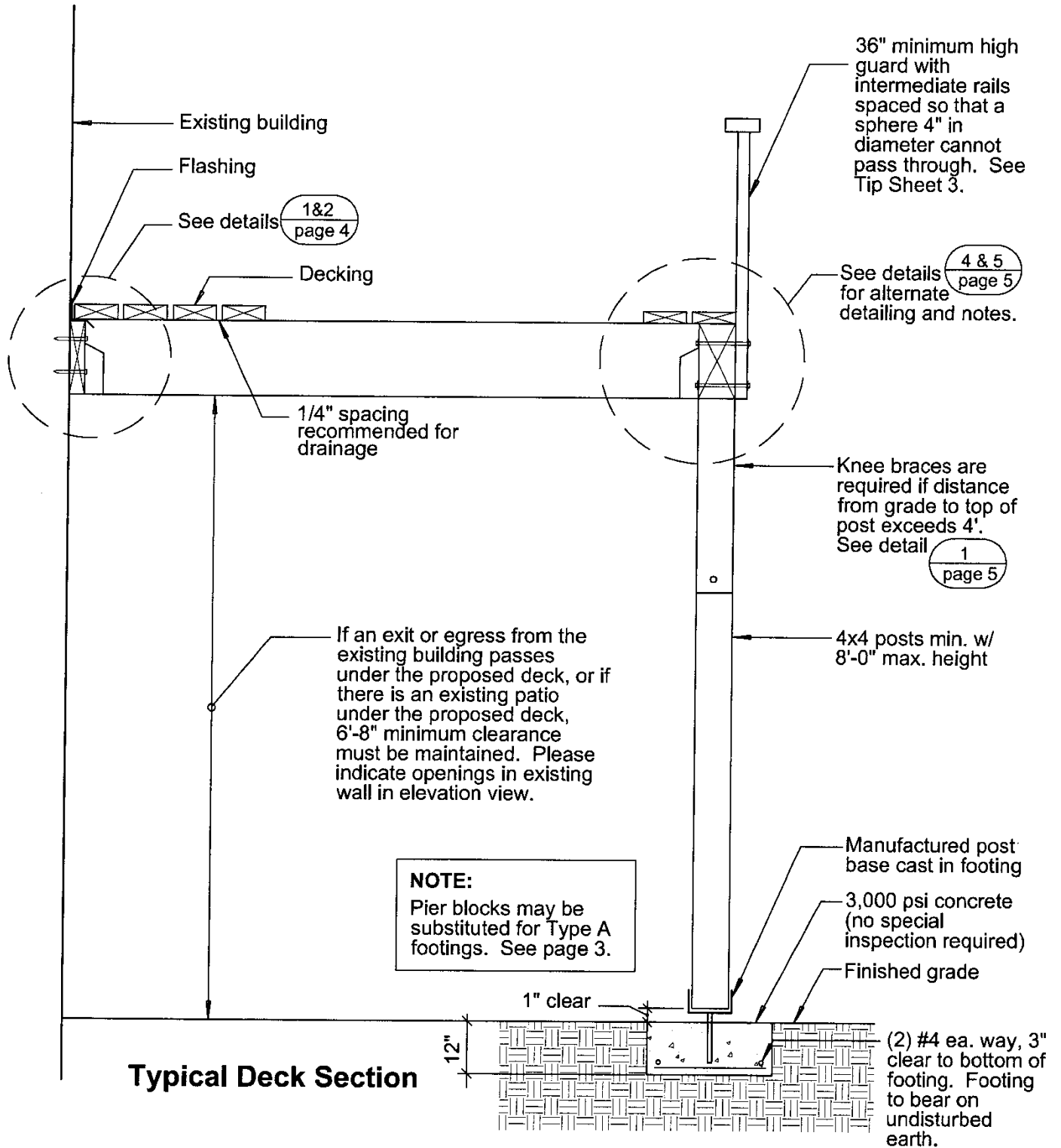

Residential Deck Requirements

Drawing - page 3

Span Table Footing Schedule For Outside Decks

Spans based on use of No.2 Hem-Fir or better

50 p.s.f. loading (10 p.s.f. Dead Load + 40 p.s.f. Live Load)

Beam spans and footings assume maximum 24" overhang

Joist size	Spacing of joists	Max. span of joists	3/8"Ø x 4 1/2" lag screw max. spacing on 2x ledger	Max. span of girder beams between posts / footing type					
				4x6	Footing	4x8	Footing	4x10	Footing
2X6	@ 12 in	9 ft - 10 in	5 in	5 ft - 5 in	B	7 ft - 2 in	B	8 ft - 10 in	C
	@ 16 in	8 ft - 9 in	6 in	5 ft - 8 in	B	7 ft - 6 in	B	9 ft - 2 in	B
	@ 24 in	7 ft - 1 in	7 in	6 ft - 1 in	B	8 ft - 0 in	B	9 ft - 10 in	B
2X8	@ 12 in	12 ft - 9 in	4 in	4 ft - 11 in	B	6 ft - 6 in	B	8 ft - 0 in	B
	@ 16 in	11 ft - 1 in	4 in	5 ft - 2 in	A	6 ft - 11 in	B	8 ft - 5 in	C
	@ 24 in	9 ft - 0 in	5 in	5 ft - 7 in	B	7 ft - 5 in	B	9 ft - 1 in	B
2X10	@ 12 in	15 ft - 7 in	3 in	4 ft - 7 in	B	6 ft - 0 in	B	7 ft - 5 in	C
	@ 16 in	13 ft - 6 in	3 in	4 ft - 10 in	B	6 ft - 5 in	B	7 ft - 10 in	C
	@ 24 in	11 ft - 0 in	4 in	5 ft - 3 in	A	6 ft - 11 in	B	8 ft - 5 in	B

FOOTING TYPES

TYPE	SIZE	NOTE:
A	12" X 12" X 12"	Pier blocks may be substituted for Type A footings
B	16" X 16" X 12"	
C	18" x 18" x 12"	

*Footing sizes based on assumed soil bearing pressure of 2000 p.s.f. Contact your jurisdiction for additional restrictions.

Deck Construction Connections

All fasteners, nails, bolts, screws, etc. must be corrosion resistant. See Deck

Construction Note 3, page 1.

Follow manufacturer's instructions for timber connectors.

Connections		Nailing
1	Joist on deck beam; toenail each end	(3) 8d
2	Bridging or blocking to joist; toenail ea. side, ea. end	(3) 8d
3	2x decking to joist or deck beam; blind and face nail	(2) 16d

Residential Deck Requirements

Drawing - page 4

NOTE:

Refer to Deck Construction Note 3, page 1 for requirements on corrosion resistance.

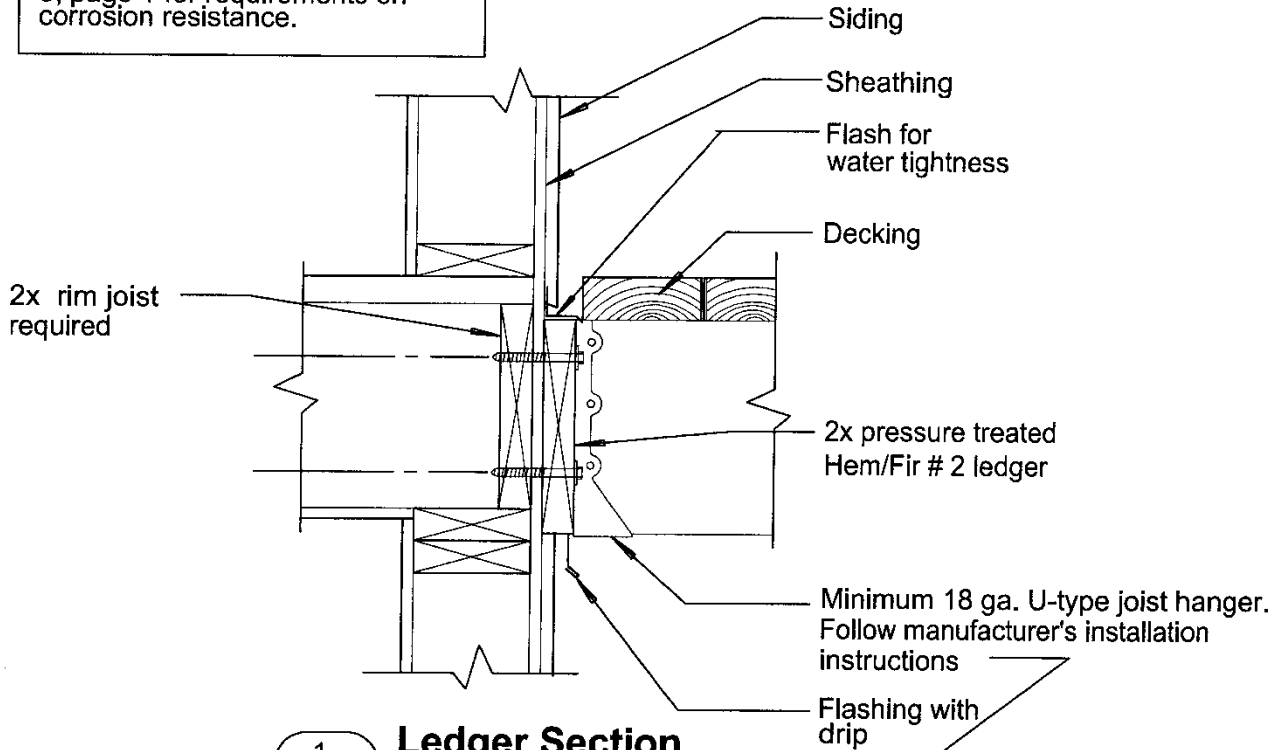

1
page 4
Ledger Section

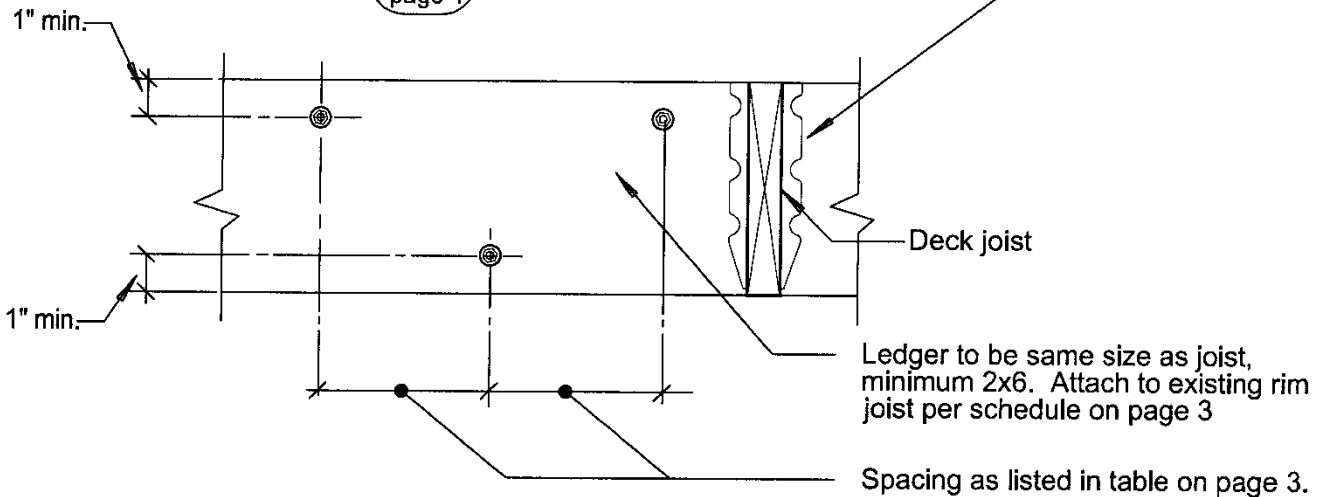

2
page 4
Ledger Elevation

Residential Deck Requirements

Drawing - page 5

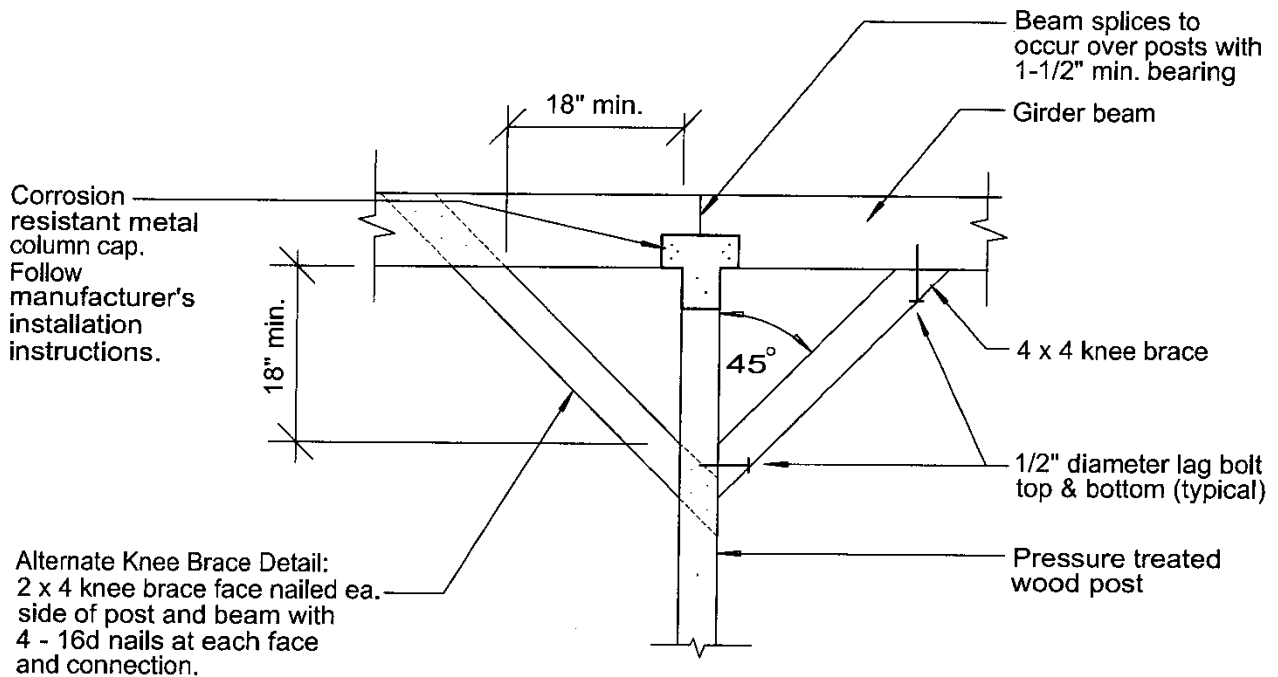

3
page 5

Knee Brace Detail

NOTE:

Knee braces are required if distance from grade to top of post exceeds 4 feet.

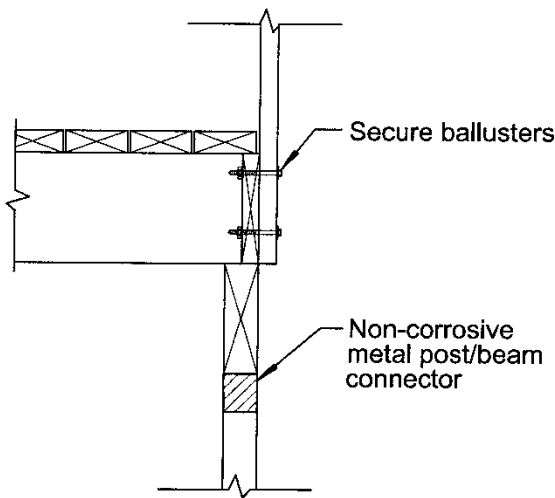

4
page 5

Alternate Joist-to-Beam Condition

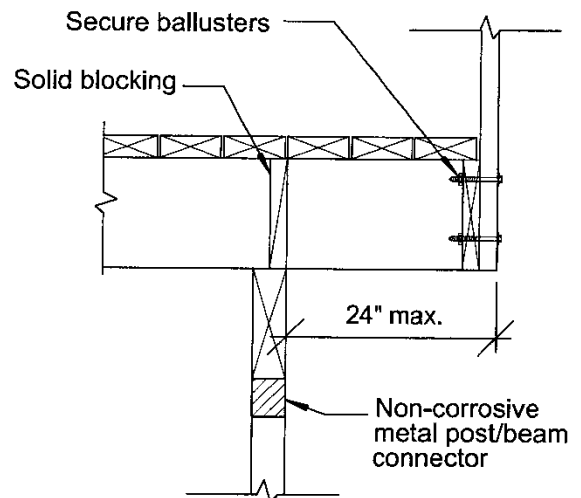

5
page 5

Alternate Joist-to-Beam Condition

Residential Deck Requirements

Drawing - page 6

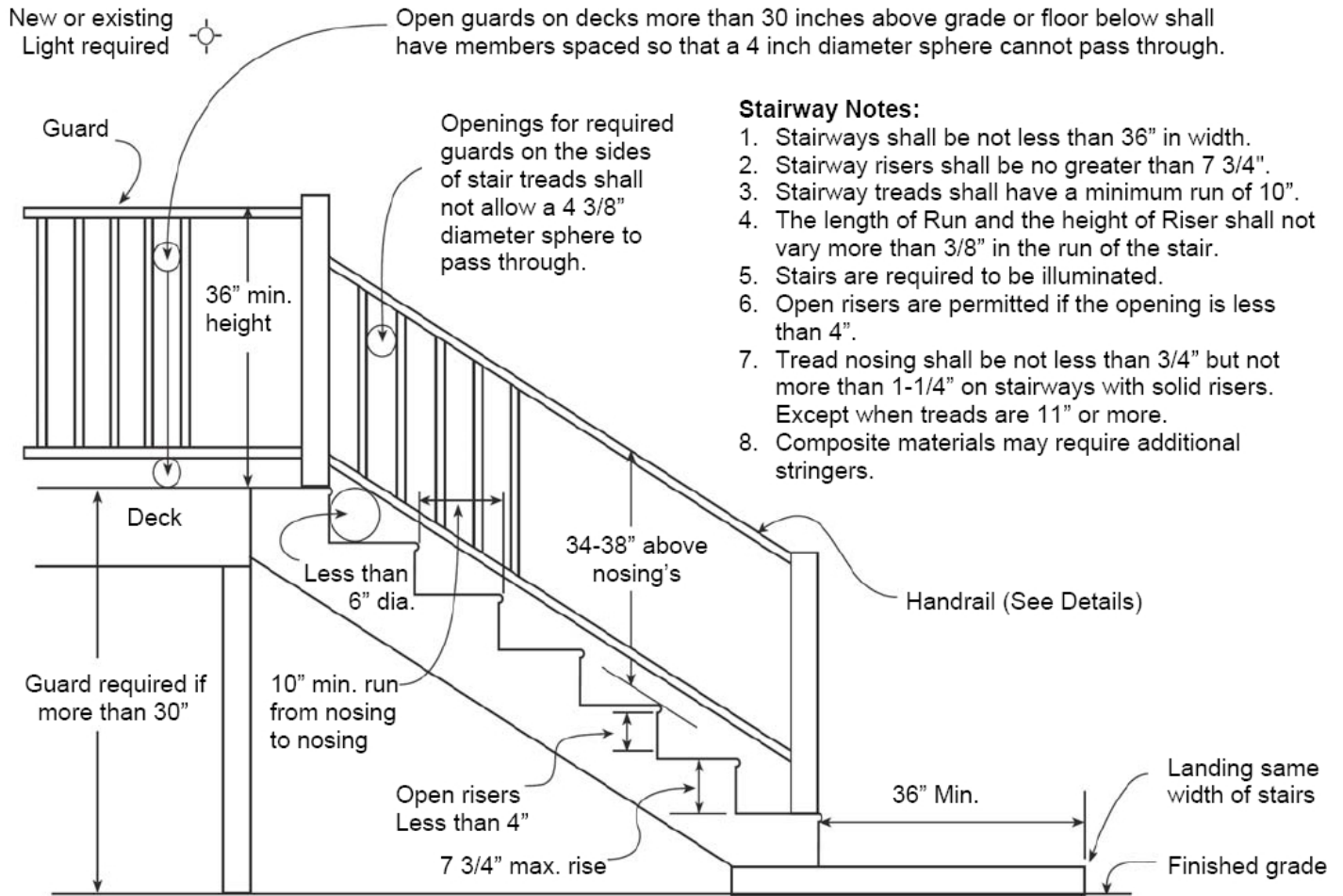

Stairway Notes:

1. Stairways shall be not less than 36" in width.
2. Stairway risers shall be no greater than 7 3/4".
3. Stairway treads shall have a minimum run of 10".
4. The length of Run and the height of Riser shall not vary more than 3/8" in the run of the stair.
5. Stairs are required to be illuminated.
6. Open risers are permitted if the opening is less than 4".
7. Tread nosing shall be not less than 3/4" but not more than 1-1/4" on stairways with solid risers. Except when treads are 11" or more.
8. Composite materials may require additional stringers.